

FIG.1

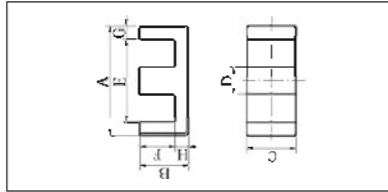

FIG.2

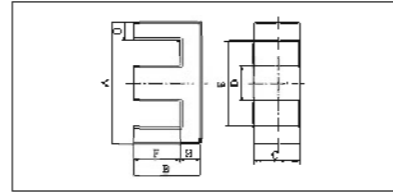

FIG.3

EE 型 / EE Core

型号 TYPE	图例 FIG.	尺寸 Dimensions (mm)					
		A	B	C	D	E	F
EE5/5/2J	1	5.25±0.15	2.65±0.1	1.95±0.1	1.35±0.1	3.8min	2±0.1
EE6.3/6/2B	1	6.3+0/-0.25	2.9±0.1	2.0±0.1	1.4±0.1	3.6min	1.9±0.1
EE8.3/10.8/3.9	1	8.3+0.25/-0.2	5.4±0.15	3.85±0.15	2.1±0.1	6.2+0.35/-0	4.4±0.15
EE8.3/8/4AA	2	8.3±0.3	4.0±0.2	3.9±0.2	2.0+0/-0.3	6.0min	3.0+0.2/-0.1
EE8.3/8/4CC	1	8.3+0.2/-0.3	4±0.2	3.9±0.15	2.15+0.05/-0.15	6.3min	3+0.2/-0.1
EE8.8/8.1/3.9	2	8.7+0.3/-0.2	4+0.2/-0.1	3.9±0.1	2.1±0.1	6.6+0.35/-0	3+0.2/-0.1
EE10.2/13.1/4.8	3	10.2±0.2	6.55±0.1	4.8±0.15	2.4±0.15	7.85±0.2	5.35±0.15
EE10/11/5H	1	10.2±0.3	5.5±0.2	4.8±0.3	2.5±0.2	7.5min	4.3±0.2
EE13.1/13.9/3.6A	3	11+0.25	6±0.15	3.1±0.2	2.5±0.2	7.6±0.25	3.85±0.15
EE11/12/3A	3	11.4±0.3	6.4±0.2	3.85±0.2	2.8±0.15	8.6±0.3	4.95±0.2
EE11.4/12.8/3.9	3	12.6+0.5/-0.4	6.3+0.1/-0.2	3.6±0.2	3.65±0.15	8.8min	4.65+0.15/-0.2

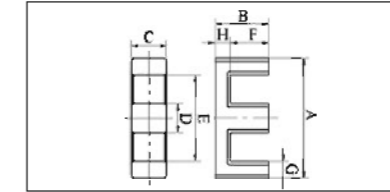
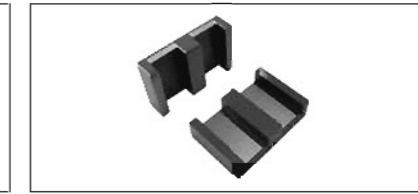
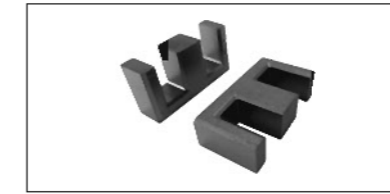

FIG.4

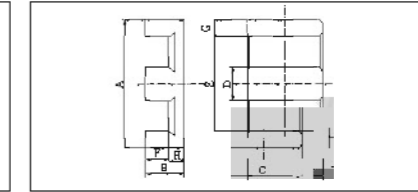

FIG.5

C1	Ae	Le	Amin	Ve	AL(±25%)				重量 g / PRS
					TS5	TS7	TS10镜面	TS13镜面	
4.93	2.57	12.66	2.53	32.50	400	530	960min	1200min	0.24
3.5	3.53	12.34	2.80	43.60	480	530	1100min	1300min	0.20
3.22	7.76	25.01	7.51	194.10	920	1050	1500min	1680min	1.00
2.63	7.46	19.63	7.21	146.50	1050	1200	1500 min	1800 min	0.80
2.7	7.21	19.47	6.44	140.40	1050	1190	1500 min	1800 min	0.73
2.54	7.89	20.03	7.70	158.00	1150	1300	1750 min	2000 min	0.82
2.68	11.43	30.6	11.28	349.70	1360	1580	1960 min	2300 min	1.80
2.25	11.69	26.3	11.52	307.40	1500	1730	2100 min	2500 min	1.60
2.61	9.63	25.16	7.75	242.30	1250	1450	1900 min	2100 min	1.30
2.76	10.88	30.07	10.78	327.20	1300	1500	1900min	2240min	1.70
2.38	12.36	29.38	11.66	363.10	1500	1750	2150min	2550min	1.90

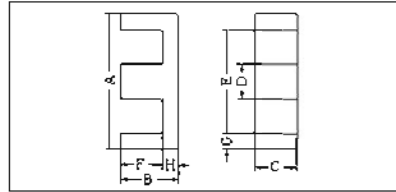
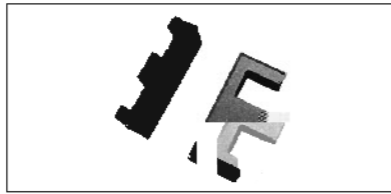

FIG.1

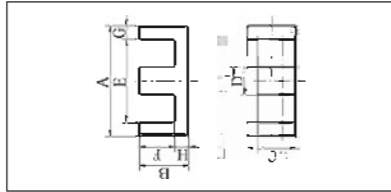

FIG.2

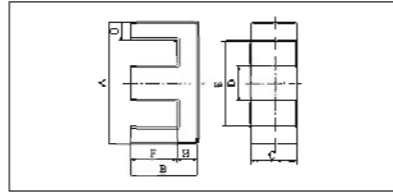

FIG.3

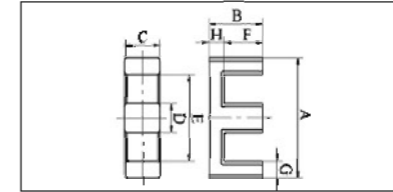

FIG.4

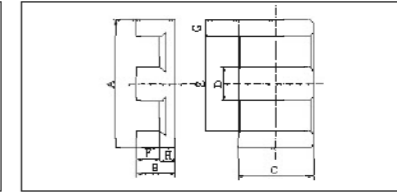
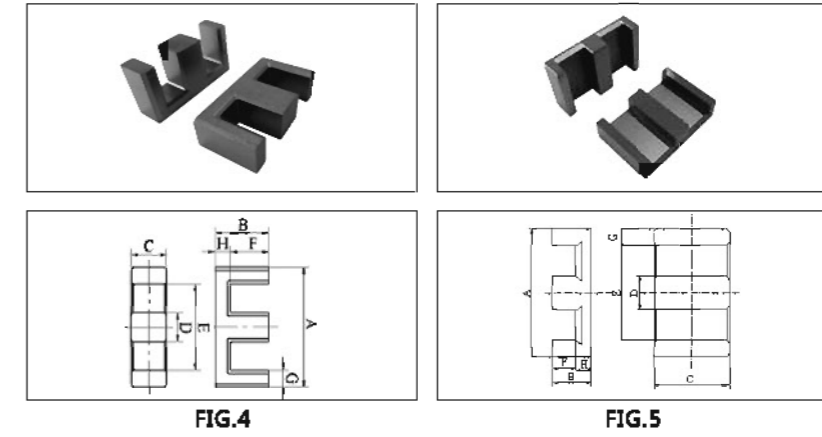
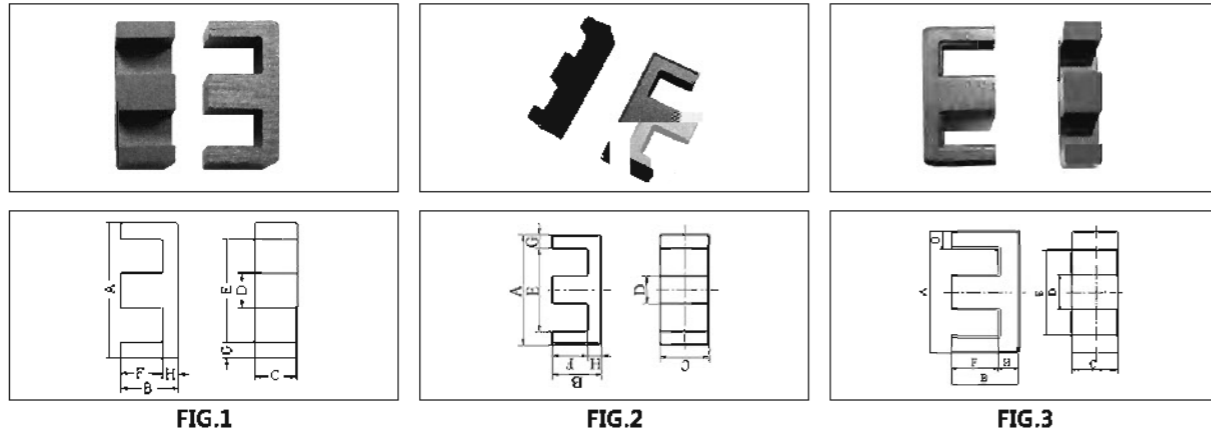

FIG.5

EE 型 / EE Core

型号 TYPE	图例 FIG.	尺寸 Dimensions (mm)					
		A	B	C	D	E	F
EE16.5/13/9	1	16.48±0.3	6.5+0.1/-0.25	9±0.2	3.18+0/-0.3	9.78min	4+0.4/-0
EE16/25/5E	3	16.8±0.2	12.5±0.3	4.85±0.2	4.0±0.15	12.5min	10.3±0.3
EE17.5/15/4.9	3	17.5±0.3	7.5±0.2	4.9±0.2	4.7±0.15	12.7min	5.3±0.15

C1	Ae	Le	Amin	Ve	AL(±25%)				重量 g / PRS
					TS5	TS7	TS10镜面	TS10镜面	
0.8	35.61	28.63	27.27	1019.50	3650	4100	6400min	7400min	5.30
2.83	19.96	56.48	19.40	1127.30	1450	1750	2300min	2800min	5.86
1.65	22.2	36.55	21.56	811.30	2050	2350	3400min	4050min	4.22



EE 型 / EE Core

型号 TYPE	图例 FIG.	尺寸 Dimensions (mm)					
		A	B	C	D	E	F
EE25/20/6H	4	25.6±0.5	10.0±0.3	6.35±0.3	6.35±0.3	18.8min	6.8±0.25
EE30/30/7B	3	30.5±0.5	15±0.3	7±0.3	6.9±0.3	19.5min	10.2±0.3
EE32/32/9V	4	32.1±0.8	16.4±0.3	9.15±0.35	9.2±0.3	23.2±0.5	11.8±0.3
EE35/29/9O	3	34.5±1.0	14.5±0.3	9.2±0.3	9.4±0.3	25.5min	9.9±0.3
EE35/29/9J	3	35±0.6	14.6±0.3	9.2±0.3	9.4±0.3	25.1min	9.8±0.3
EE35/30/9	3	35.0±0.6	14.6±0.3	9.2±0.3	9.4±0.3	24.8min	9.8±0.3
EE36/37/15B	3	36±0.6	18.6+0/-0.4	15.1+0/-0.5	10.2+0/-0.5	25±0.4	12.8+0.5/-0
EE40/35/12B	4	40.0±0.7	17.3±0.3	12.0+0/-0.6	12.0+0/-0.6	26.8min	10.3±0.3
EE41/34/13A	4	40.6±0.6	16.5±0.3	12.5±0.3	12.5±0.3	28.6min	10.5±0.3
EE43.2/19.1/27.9	5	43.2±0.51	9.55±0.2	27.9±0.38	8.1±0.2	34.7min	5.7±0.2

C1	Ae	Le	Amin	Ve	AL(±25%)				重量 g / PRS
					TS5	TS7	TS10镜面	TS13镜面	
1.24	40.33	50.14	40.01	2022.30	3150	3700	5050min	6050min	10.50
1.12	59.03	66.07	48.30	3900.30	3900	4700	6000min	7350min	20.30
0.91	83.16	75.52	81.44	6280.00	5050	6100	7600min	9300min	32.60
0.87	80.88	70.42	73.60	5695.60	5100	6200	7700min	9450min	29.60
0.81	86.77	70.37	85.56	6106.40	5500	6650	8400min	10100min	31.80
0.8	87.69	70.2	86.48	6155.40	5550	6700	8400min	10500min	32.00
0.54	155.62	83.74	147.02	13030.20	8800	10500	13200min	16000min	67.80
0.52	148.23	77.13	136.89	11433.00	8850	10500	13300min	16450min	59.50
0.52	149.22	77.41	142.50	11551.40	8890	10800	13300min	16450min	60.10
0.28	221.68	61.95	214.83	13733.10	15000	18000	22000min	28000min	71.40